

PAS 432S (17") Separation System

Low Shock Satellite Separation System for your mission

The RUAG 432S Separation System is designed for a first application for satellites up to 200 kg @ 0.45 m on the VEGA launch vehicle.

The Separation System includes a low shock clamp band separation system, interface rings, umbilical connection and a separation spring set. With our CBOD-LT™ Separation System Release Mechanism we can provide the unique combination of high load capability and a low shock release.

Building on heritage and reliability

The PAS 432S Separation System is based on the already flight proven systems at RUAG. Developed for over 30 years, the RUAG Space product family to date includes a broad range of Separation Systems, spanning diameters from 381 mm to 2624 mm (15" to 103").

Our Separation Systems have an outstanding flight record. To date more than 550 in-orbit separations have been carried out with a success rate of 100%! Our customer base includes launch service providers, satellite builders, government entities and national space agencies. We work closely with the customers during the spacecraft design phase to establish a fully compatible design.

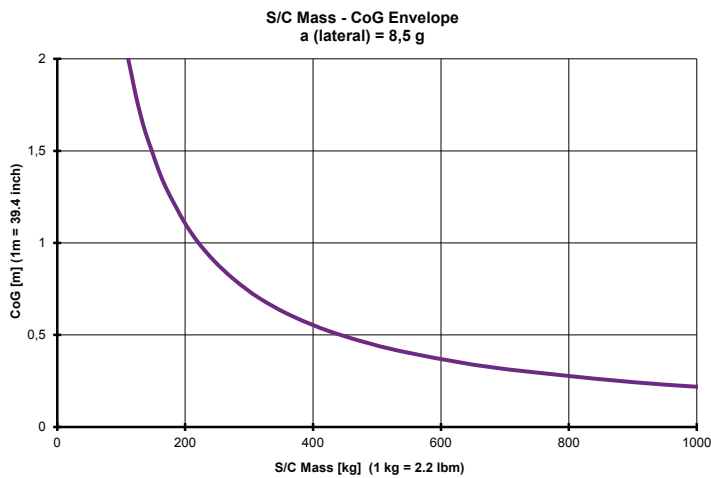
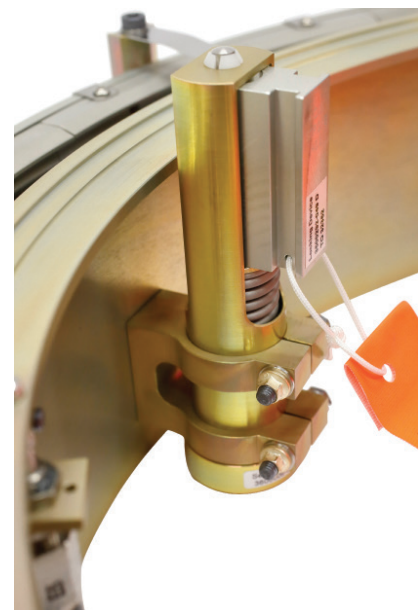
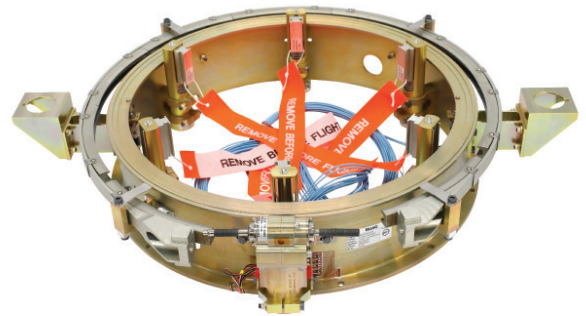

Main characteristics of PAS 432S

		Unit	Value
Bolt pretension (nominal)		kN	15
Mass	Total ¹⁾	kg	7.2
	Separated mass	kg	1.9
Dimensions	Height ²⁾	mm	123
I/F	Passive ring	12 x 8.5 mm holes on a diameter of 298 mm (may be modified)	
	Active ring	12 x 6.8 mm holes on a diameter of 437 mm	
	Initiator type	Pacific Scientific 103377-449 Hi-Shear PC23-250 ASI PD22240024-009 USI 1F01084-1	
Separation springs	No. of springs	pcs	6
	Spring energy ³⁾	Joule	4.7
Release type		CBOD-LT	
Shock output		Low shock < 100 g's @ 1 kHz	

¹⁾ Mass of the standard system including passive ring. Can be optimized to meet specific needs.

²⁾ Height includes active ring and separation springs.

³⁾ Energy per spring.

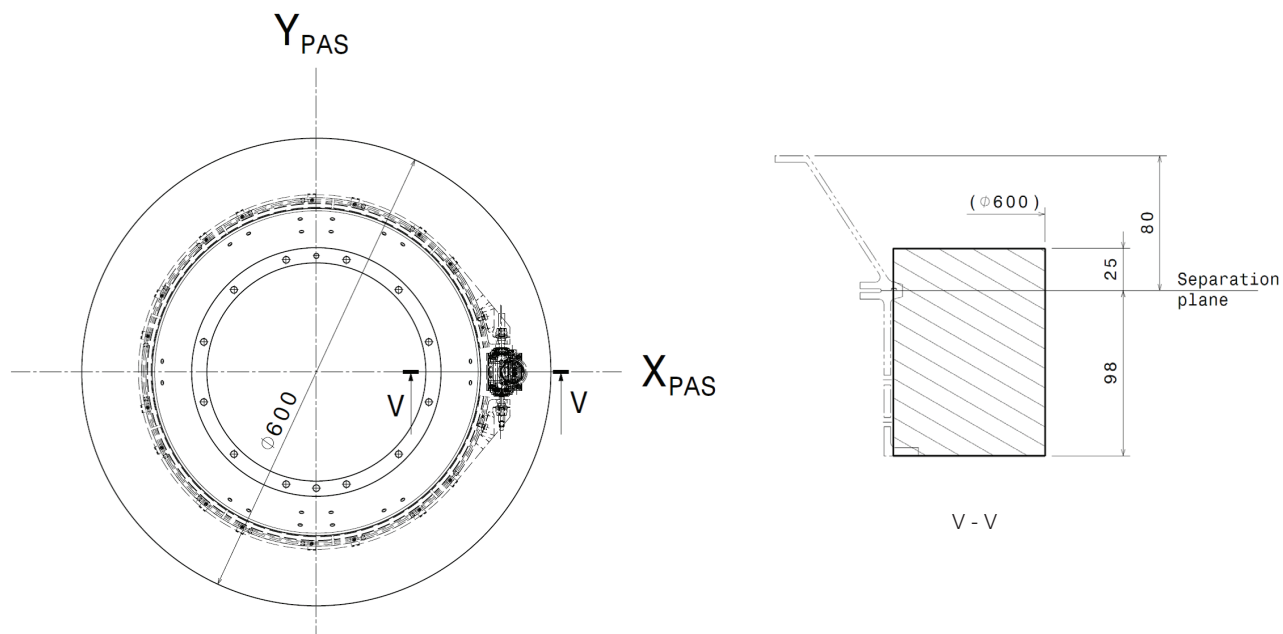

Illustrative Drawing and Nominal Release Envelopes